



US 20060244696A1

(19) **United States**

(12) **Patent Application Publication**

Jung et al.

(10) **Pub. No.: US 2006/0244696 A1**

(43) **Pub. Date: Nov. 2, 2006**

(54) **ORGANIC LIGHT EMITTING DIODE DISPLAY**

(30) **Foreign Application Priority Data**

May 2, 2005 (KR)..... 10-2005-0036756

(75) Inventors: **Kwang-Chul Jung**, Seongnam-si (KR);
In-Su Joo, Seongnam-si (KR)

Publication Classification

(51) **Int. Cl.**
G09G 3/30 (2006.01)

(52) **U.S. Cl.** 345/77

Correspondence Address:
David W. Heid
MacPHERSON KWOK CHEN & HEID LLP
Suite 226
1762 Technology Drive
San Jose, CA 95110 (US)

(57) **ABSTRACT**

An organic light emitting diode display includes a plurality of pixels. Each pixel includes a light emitting element and a driving transistor coupled to the light emitting element. The pixels may be arranged in a matrix. The pixels include first pixels, second pixels, and third pixels, the driving transistors of the first to the third pixels occupy different areas, and the light emitting elements of the first to the third pixels occupy substantially equal area.

(73) Assignee: **Samsung Electronics Co., Ltd.**

(21) Appl. No.: **11/413,240**

(22) Filed: **Apr. 28, 2006**

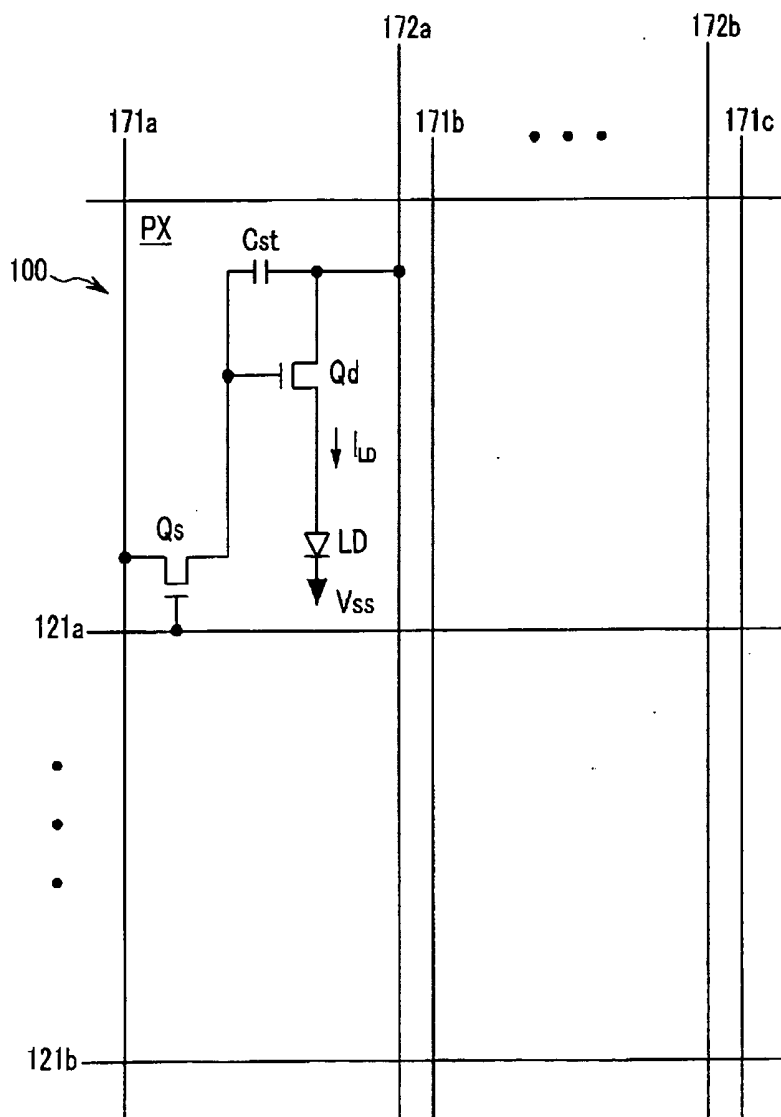

FIG. 1

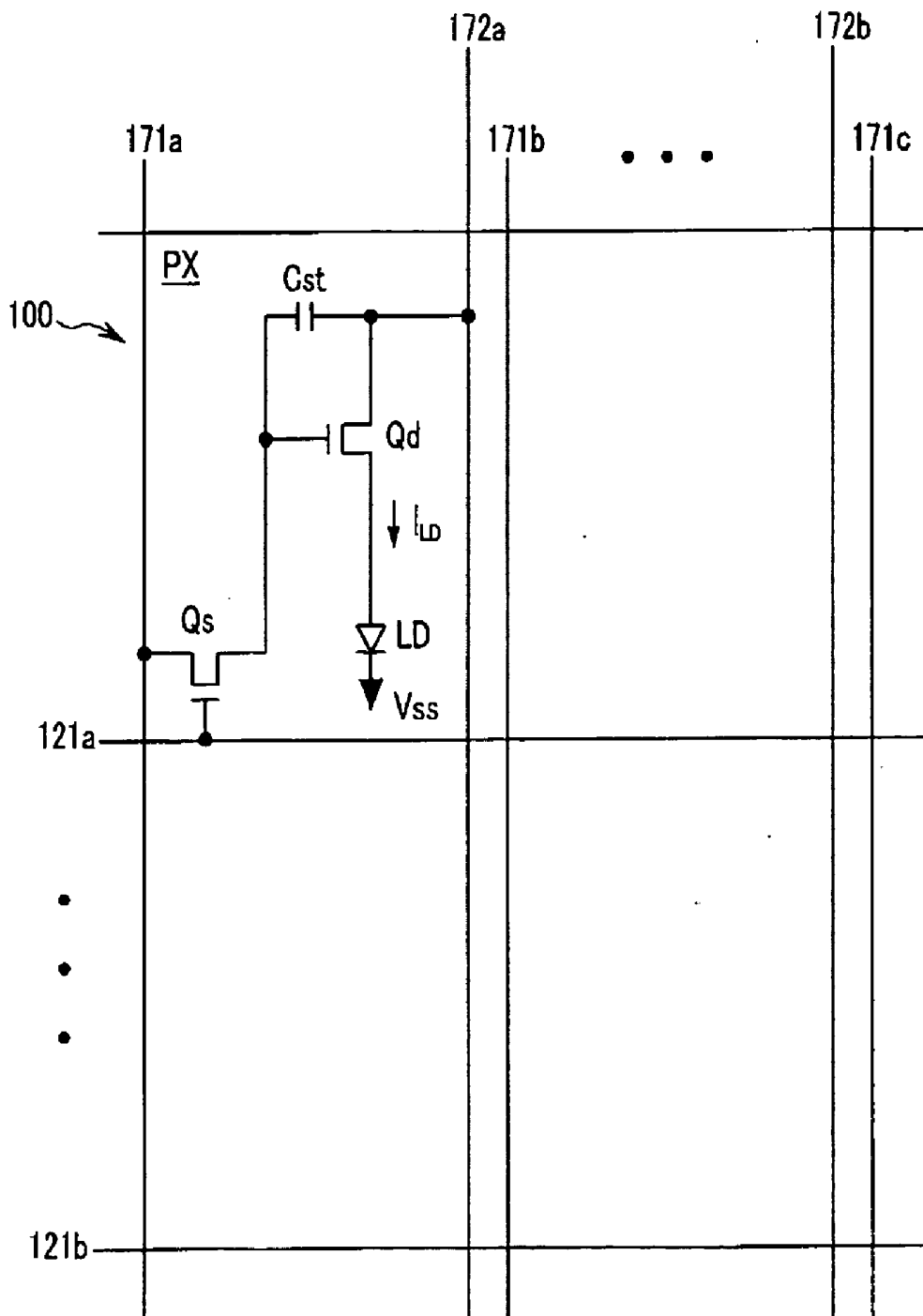

FIG. 2

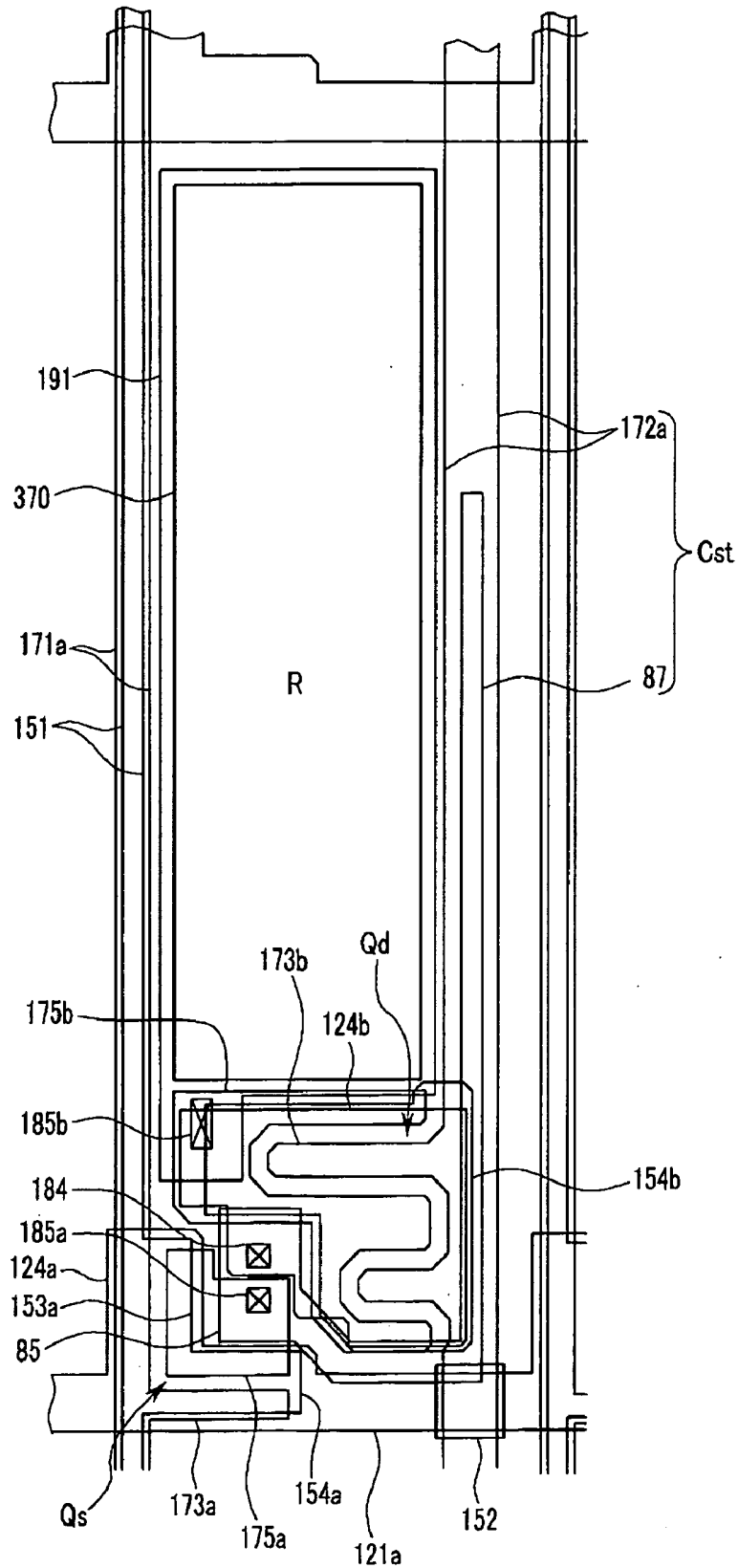

FIG. 3

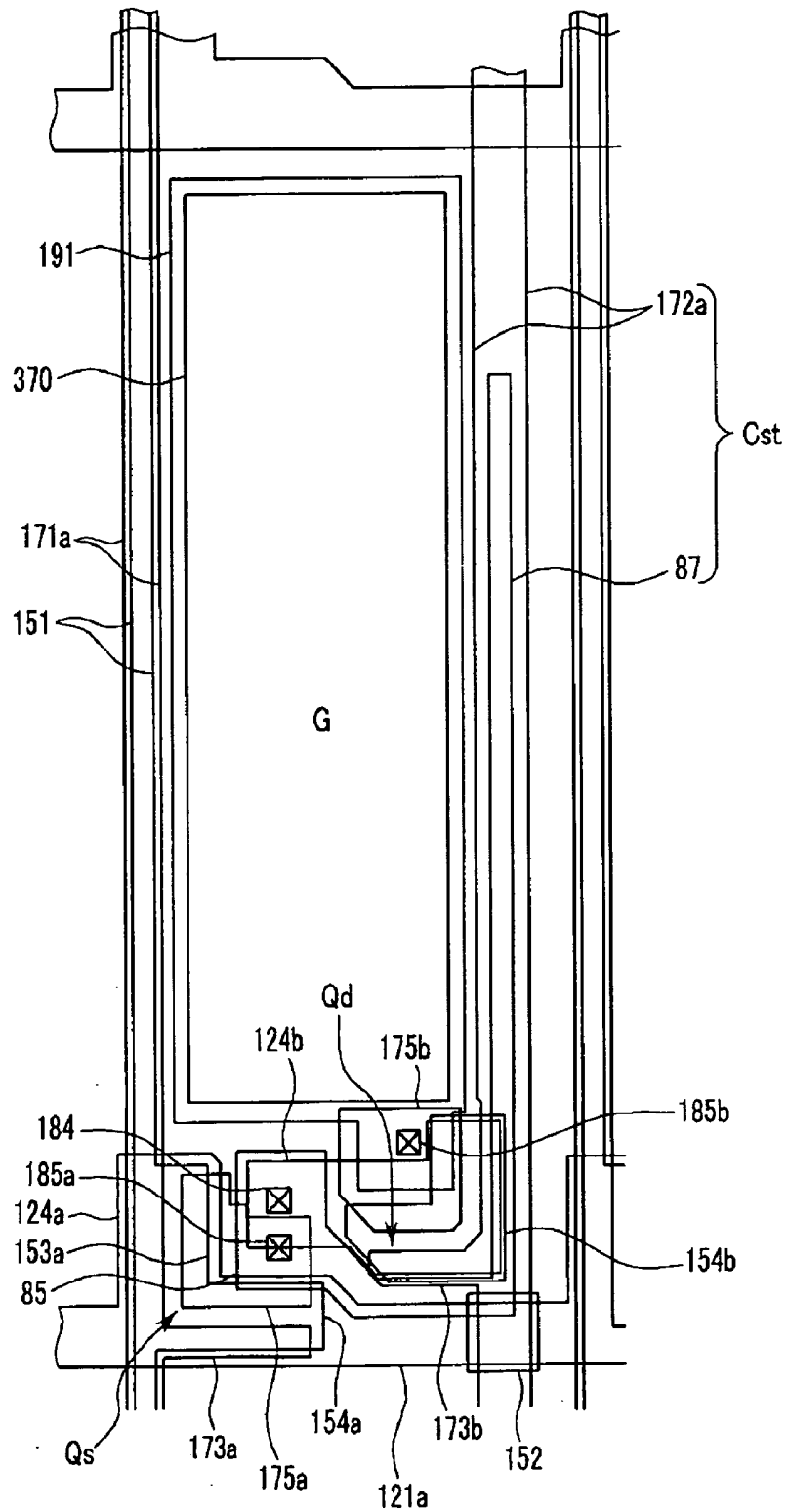

FIG. 4

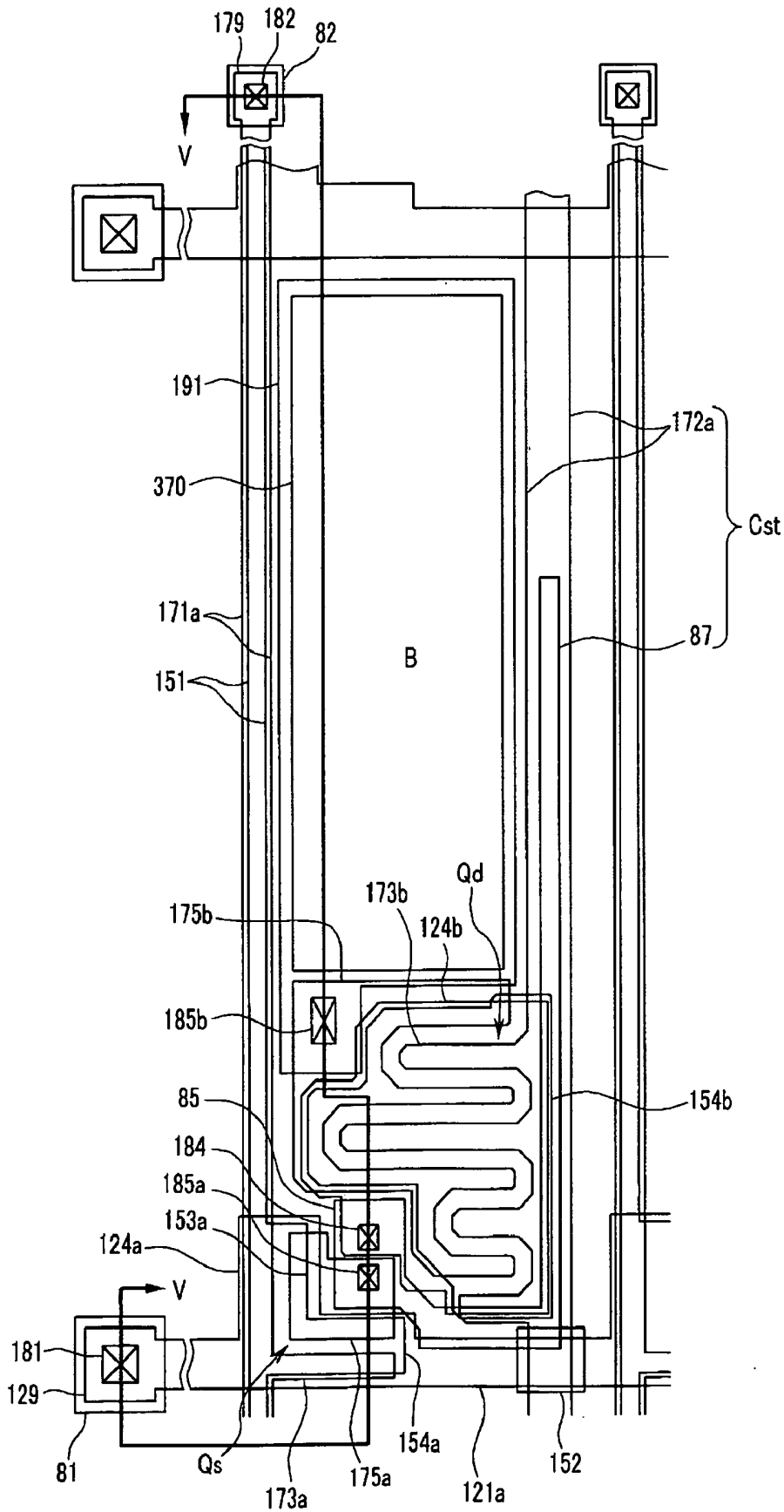

FIG. 5

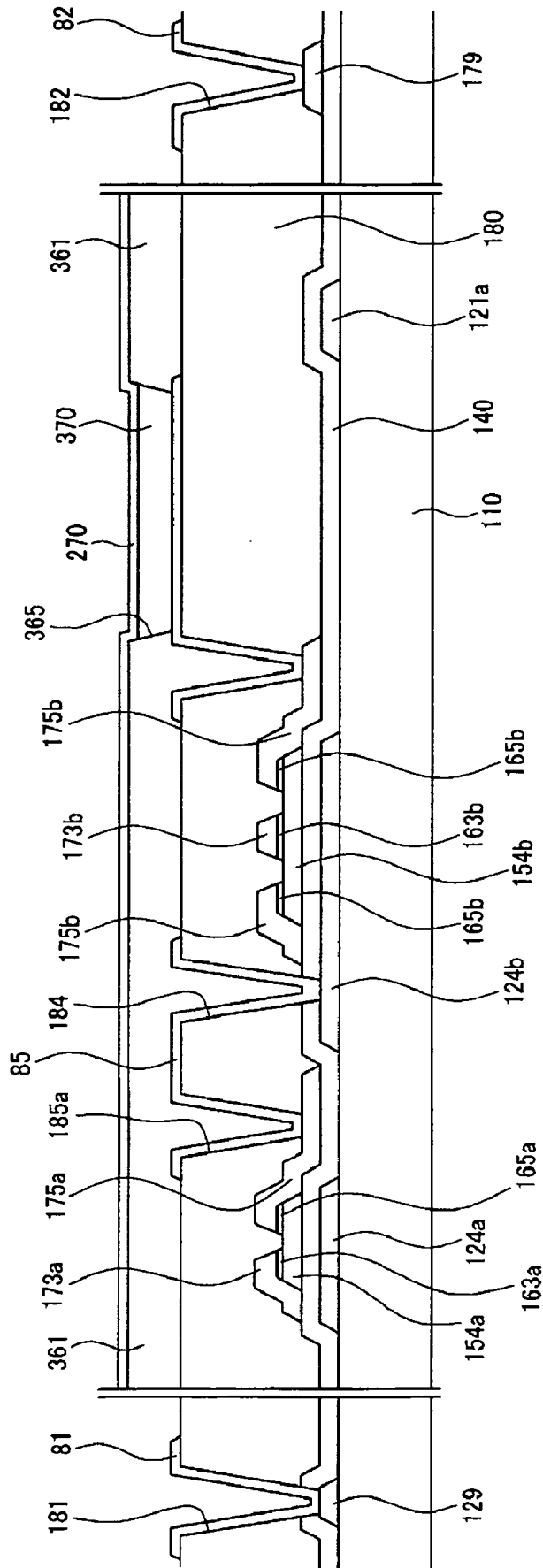
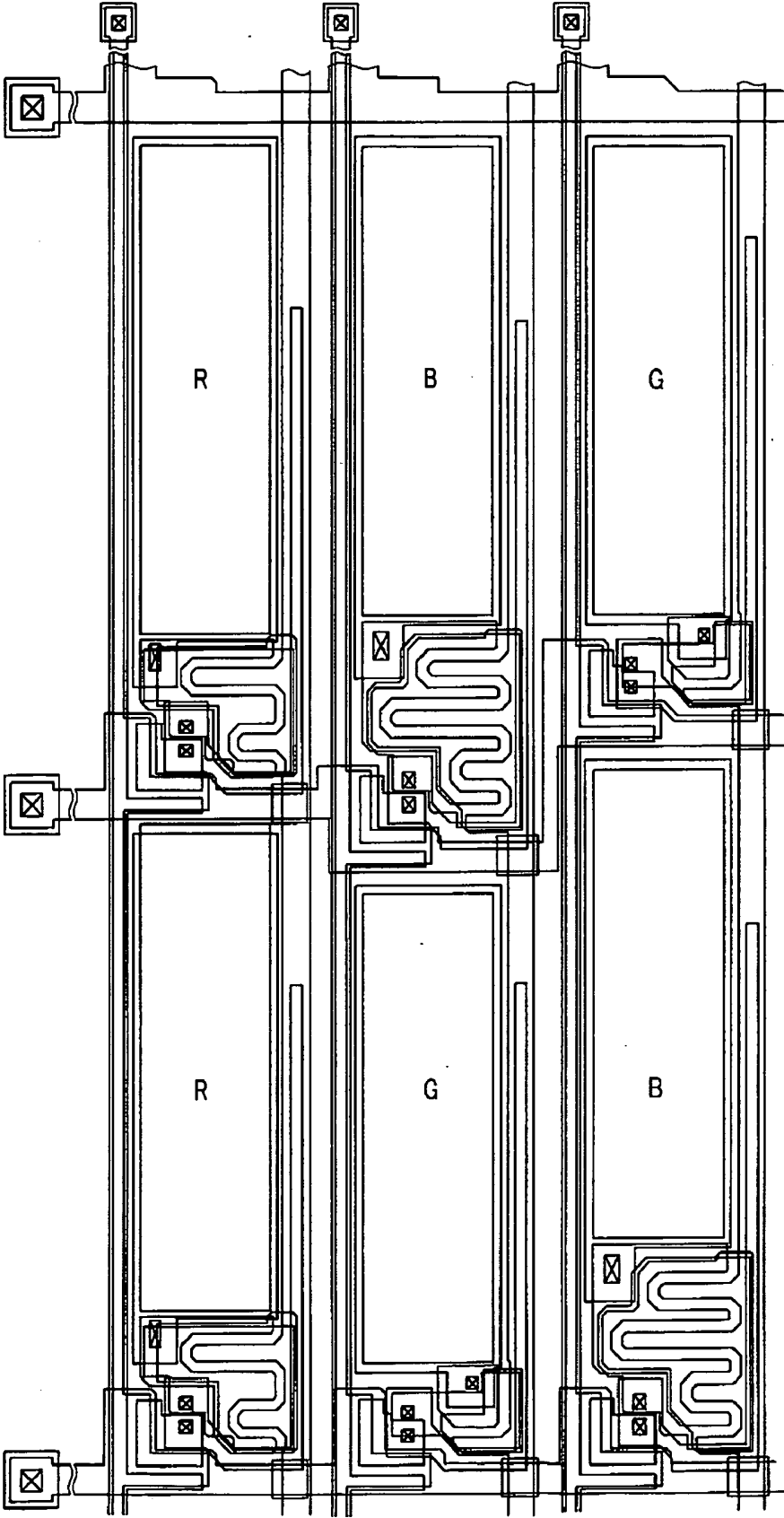

FIG.6



ORGANIC LIGHT EMITTING DIODE DISPLAY

BACKGROUND OF THE INVENTION

[0001] 1. Field of the Invention

[0002] The present invention relates to light emitting diodes, and in particular, an organic light emitting diode display.

[0003] 2. Description of Related Art

[0004] The recent trend to thin, lightweight personal computers and television sets created demands for thin, lightweight display devices. Currently, flat panel displays are satisfying these demands and are being substituted for conventional cathode ray tubes (CRT).

[0005] Exemplary flat panel displays include liquid crystal displays (LCD), field emission displays (FED), organic light emitting diode (OLED) displays, and plasma display panels (PDP). The OLED display appears to be the most promising of the flat panel displays, because of its low power consumption, fast response time, wide viewing angle, and high contrast ratio.

[0006] In general, an OLED display is a self-emissive display device, which includes two electrodes and an organic light emitting layer interposed between the two electrodes, with one electrode (anode) injecting holes into the light emitting layer and the other electrode (cathode) injecting electrons. Excitons are formed when the injected electrons and holes recombine, and emit light by discharging energy.

[0007] Because the red, green, and blue light emitting materials currently employed in OLEDs display exhibit different emission efficiencies, there is a need to design and produce pixels based on the lowest emission efficiency, in order to control red, green, and blue light emissions in an equivalent manner, and thereby decreasing pixel aperture ratio.

SUMMARY OF THE INVENTION

[0008] An organic light emitting diode display is provided, which includes a plurality of pixels. Each pixel includes a light emitting element and a driving transistor coupled to the light emitting element. The pixels may be arranged in a matrix.

[0009] According to an embodiment of the present invention, the pixels include first pixels, second pixels, and third pixels, the driving transistors of the first to the third pixels occupy different areas, and the light emitting elements of the first to the third pixels occupy substantially equal area.

[0010] According to another embodiment of the present invention, the pixels include first pixels, second pixels, and third pixels, the driving transistors of the first to the third pixels occupy different areas, and the matrix includes a first pixel column including second pixels and a second pixel column including the first pixels and the second pixels that are alternately arranged.

[0011] According to another embodiment of the present invention, the matrix includes a plurality of pixel rows, and each pixel row has a curved boundary and a straight boundary.

[0012] According to another embodiment of the present invention, the organic light emitting diode display further includes a plurality of gate lines and a plurality of data lines. The gate lines and the data lines are coupled to the pixels and define areas of the pixels, and the gate lines include periodically-curved gate lines and straight gate lines that are alternately arranged.

[0013] According to another embodiment of the present invention, the pixels comprise a first pixel, a second pixel, and a third pixel, and the first pixel, the second pixel, and third pixels have different lengths in a predetermined direction.

[0014] An organic light emitting diode display according to another embodiment of the present invention includes: a substrate; a light emitting element formed on the substrate; a driving voltage line formed on the substrate; a driving transistor coupled to the driving voltage line and the light emitting element; a gate line and a data line formed on the substrate; and a switching transistor coupled to the gate line and the data line, wherein the driving transistor has a serpentine channel.

BRIEF DESCRIPTION OF THE DRAWINGS

[0015] The present invention will become more apparent by describing embodiments thereof in detail with reference to the accompanying drawings in which:

[0016] **FIG. 1** is an equivalent circuit diagram of an OLED display pixel according to an embodiment of the present invention;

[0017] **FIGS. 2, 3 and 4** are layout views of different pixels in an OLED display according to an embodiment of the present invention;

[0018] **FIG. 5** is a sectional view of the pixel shown in **FIG. 4** taken along the line V-V; and

[0019] **FIG. 6** shows an arrangement of pixels in an OLED display according to an embodiment of the present invention.

DETAILED DESCRIPTION OF EMBODIMENTS

[0020] The present invention now will be described more fully hereinafter with reference to the accompanying drawings, in which preferred embodiments of the invention are shown. The present invention may, however, be embodied in many different forms and should not be construed as limited to the embodiments set forth herein.

[0021] In the drawings, the thickness of layers, films, panels, regions, etc. are exaggerated for clarity. Like numerals refer to like elements throughout. It will be understood that when an element such as a layer, film, region or substrate is referred to as being "on" another element, it can be directly on the other element or intervening elements may also be present. In contrast, when an element is referred to as being "directly on" another element, there are no intervening elements present.

[0022] Referring to **FIG. 1**, exemplary OLED display includes a plurality of pixels arranged substantially in a matrix, with each pixel PX **100** being connected to signal lines **121a**, **171a** and **172a**. With respect to pixel PX **100**, exemplary gate line **121a** transmits a gate signal (or scan-

ning signal), data line **171a** transmits a data signal, and driving voltage line **172a** transmits a driving voltage. In an OLED display formed from a plurality of pixels **PX 100**, gate lines **121a-b** extend substantially in a first direction and substantially parallel to each other as rows, while data lines **171a-c** and driving voltage lines **172a-b** extend substantially in a second direction and substantially parallel to each other, as columns. Typically, each pixel **PX 100** can include switching transistor **Qs**, driving transistor **Qd**, capacitor **Cst**, and OLED **LD**. Switching transistor **Qs** can have a control terminal connected to gate line **121a**, an input terminal connected to data line **171a**, and an output terminal connected to driving transistor **Qd**. Switching transistor **Qs** transmits a data signal applied to data line **171a** to driving transistor **Qd** in response to a gate signal applied to gate line **121a**. Driving transistor **Qd** can have a control terminal connected to switching transistor **Qs**, an input terminal connected to the OLED **LD**. Driving transistor **Qd** drives an output current **ILD** having a magnitude that corresponds to the voltage difference between the control terminal and the output terminal thereof. Capacitor **Cst** can be connected between the control terminal and the output terminal of driving transistor **Qd**. Capacitor **Cst** can store a data signal applied to the control terminal of driving transistor **Qd** and maintains the data signal after switching transistor **Qd** turns off. OLED **LD** can have an anode connected to the output terminal of driving transistor **Qd** and a cathode connected to a common voltage **Vss**. OLED **LD** typically emits light having an intensity corresponding to an output current **ILD** of driving transistor **Qd**, with the light thereby creating a displayed image. Desirably, switching transistor **Qs** and driving transistor **Qd** are n-channel field effect transistors (FETs). However, at least one of switching transistor **Qs** and driving transistor **Qd** may be a p-channel FET. In addition, the connections among transistors **Qs** and **Qd**, capacitor **Cst**, and OLED **LD** may be modified.

[0023] FIGS. 2-5 present detailed structures of pixel **PX 100** of the OLED display shown in FIG. 1, in which FIGS. 2, 3 and 4 are layout views of different OLED display pixels and FIG. 5 is a sectional view of the pixel shown in FIG. 4, taken along the line V-V.

[0024] An OLED display can have a plurality of gate conductors that include a gate line **121a** including first control electrodes **124a** and a plurality of second control electrodes **124b** are formed on an insulating substrate **110**. Insulating substrate **110** can be a suitable substantially transparent materials including, without limitation, glass or plastic.

[0025] Gate line **121a** extends in a substantially transverse direction. Gate line **121a** further includes an end portion **129** having a large area for contact with another layer or with an external driving circuit. First control electrode **124a** may project upward from gate line **121a**. Gate lines **121a** may extend to be directly connected to a gate driving circuit (not shown) for generating the gate signals, which may be integrated on substrate **110**. Each of second control electrodes **124b** can be separated from gate line **121a**. In one embodiment, gate conductors **121a** and **124b** are made of Al containing metal such as Al and Al alloy, Ag containing metal such as Ag and Ag alloy, Cu containing metal such as Cu and Cu alloy, Mo containing metal such as Mo and Mo alloy, Cr, Ta, Ti, etc. Gate conductors **121a** and **124b** may

have a multi-layered structure including two films having different physical characteristics. One of the two films is made of low resistivity metal including Al-containing metal, Ag-containing metal, or Cu-containing metal, for reducing signal delay or voltage drop. The other film is made of material such as Mo containing metal, Cr, Ta, or Ti, which has good physical, chemical, and electrical contact characteristics with other materials such as indium tin oxide (ITO) or indium zinc oxide (IZO). Good examples of the combination are a lower Cr film and an upper Al (alloy) film and a lower Al (alloy) film and an upper Mo (alloy) film. However, gate conductors **121a** and **124b** may be made of other various metals or conductors. The lateral sides of gate conductors **121a** and **124b** can be inclined relative to a surface of substrate **110**, with the inclination angle thereof being in the range between about 30 degrees and about 80 degrees. Gate insulating layer **140** can be formed on gate conductors **121a** and **124b**. Desirably, layer **140** can be made of silicon nitride (SiNx) or silicon oxide (SiOx). Semiconductor stripe **151** and semiconductor island **154b** can be formed on gate insulating layer **140**, and can be made of hydrogenated amorphous silicon (abbreviated to "a-Si") or polycrystalline silicon. Semiconductor stripe **151** extends substantially in a longitudinal direction and includes a plurality of projections **154a**. Semiconductor island **154b** can be disposed on second control electrode **124b**.

[0026] First ohmic contacts **163a** and **165a** and second ohmic contacts **163b** and **165b** can be formed on semiconductor stripe **151** and semiconductor island **154b**, respectively. First ohmic contacts **163a** and **165a** are located in pairs on semiconductor stripe **151**, and second ohmic contacts **163b** and **165b** are located in pairs on semiconductor island **154b**. In one embodiment, ohmic contacts **163a**, **163b**, **165a**, and **165b** include silicide, or n+hydrogenated a-Si, which can be heavily doped with an n-type impurity, such as phosphorous.

[0027] A plurality of data conductors including data line **171a**, driving voltage line **172a**, and first and second output electrodes **175a** and **175b** can be formed on ohmic contacts **163a**, **163b**, **165b**, and **165b**, and gate insulating layer **140**. Data line **171a** for transmitting data signals can extend substantially in the longitudinal direction and can intersect gate line **121a**. Data line **171a** includes first input electrode **173a** extending toward first control electrode **124a**, and end portion **179** having a large area for contact with another layer, or with an external driving circuit. Data line **171a** may extend to be directly connected to a data driving circuit (not shown) for generating the data signals, and may be integrated on substrate **110**. Driving voltage line **172a** for transmitting driving voltages extends substantially in the longitudinal direction and intersects gate line **121a**. Driving voltage line **172a** includes a plurality of second input electrodes **173b** extending toward second control electrodes **124b**.

[0028] First and second output electrodes **175a** and **175b** can be separated from each other and from data line **171a** and driving voltage line **172a**. Each pair of first input electrodes **173a** and first output electrodes **175a** are disposed opposite each other with respect to a first control electrode **124a**, and each pair of second input electrodes **173b** and second output electrodes **175b** are disposed opposite each other with respect to a second control electrode **124b**. Data conductors **171a**, **172a**, **175a** and **175b** can be made of

refractory metal including, without limitation, Mo, Cr, Ta, Ti, or alloys thereof. In addition, it may be beneficial to form conductors **171a**, **172a**, **175a**, and **175b** in a multi-layered structure including, without limitation, refractory metal film layer and a low resistivity film layer. Suitable exemplary multi-layered structures include, without limitation, a double-layered structure including a lower Cr film layer and an upper Al (Al-alloy) film layer; a double-layered structure including a lower Mo (or Mo-alloy) film layer and an upper Al (alloy) film layer; and a triple-layered structure of a lower Mo (or Mo-alloy) film layer, an intermediate Al (or Al-alloy) film layer, and an upper Mo (or Mo-alloy) film layer. However, data conductors **171a**, **172a**, **175a** and **175b** may be made of other suitable conductive materials. Like gate conductors **121a** and **124b**, data conductors **171a**, **172a**, **175a** and **175b** have inclined edge profiles, with the inclination angles thereof being in a range between about 30 degrees and about 80 degrees.

[0029] Ohmic contacts **163a**, **163b**, **165b**, and **165b** are interposed between the underlying semiconductor members **151** and **154b** and overlying data conductors **171a**, **172a**, **175a** and **175b** to reduce the contact resistance therebetween. Semiconductor members **151** and **154b** may include exposed portions, which are not covered with data conductors **171a**, **172a**, **175a**, and **175b**, in the manner by which portions disposed between input electrodes **173a** and **173b** and output electrodes **175a** and **175b** are covered.

[0030] Passivation layer **180** can be formed on data conductors **171a**, **172a**, **175a**, and **175b**, and on the exposed portions of semiconductor members **151** and **154b**. It is desirable to make passivation layer **180** of an insulator, and may be an inorganic insulator or an organic insulator. Layer **180** may be configured to have a top surface that is substantially flat. Examples of suitable inorganic insulators include silicon nitride and silicon oxide. Exemplary organic insulators can exhibit a dielectric constant having a value of less than about 4.0; and may exhibit photosensitivity. Passivation layer **180** also may be multilayered, with an exemplary multilayered structure including a lower film layer of an inorganic insulator and an upper film layer of organic insulator, such that it exhibits the excellent insulating characteristics of an organic insulator while preventing damage by the organic insulator to the exposed portions of semiconductor members **151** and **154b**. Passivation layer **180** can have contact holes **182**, **185a**, and **185b** exposing end portion **179** of data line **171a**, first output electrode **175a**, and second output electrode **175b**, respectively. Similarly, passivation layer **180** and gate insulating layer **140** can have contact holes **181** and **184** exposing end portion **129** of gate line **121a** and second control electrode **124b**, respectively. Pixel electrode **191**, connecting member **85**, and contact assistants **81** and **82** can be formed on passivation layer **180**, and can be made of transparent conductor such as ITO or IZO, as well as of a reflective conductor, including without limitation, Al, Ag, and alloys thereof. Pixel electrode **191** is connected to second output electrode **175b** through contact holes **185b**. Connecting member **85** can be connected to second control electrode **124b** and first output electrode **175a** through contact holes **184** and **185b**, respectively. Connecting member **85** includes storage electrode **87**, extending to overlap along a driving voltage line **172a**. Contact assistants **81** and **82** can be connected to end portion **129** of gate line **121a** and end portion **179** of data line **171a** through contact holes **181** and **182**, respectively. Contact

assistants **81** and **82** protect end portions **129** and **179** and can enhance the adhesion between end portions **129** and **179** and external devices.

[0031] It is desirable to form partition **361** on passivation layer **180**. Partition **361** can surround pixel electrode **191** to define opening **365**, and can be made of organic or inorganic insulating material. Partition **361** may be made of a photo-sensitive material, which may contain a black pigment so that black partition **361** may serve as a light blocking member and the formation of partition **361** may be simplified.

[0032] An OLED display according to embodiments of the present invention can include a plurality of light emitting members, such as light emitting member **370**. Light emitting member **370** can be formed on pixel electrodes **191** and generally confined in opening **365** defined by partition **361**. Light emitting members **370** can be made of organic material uniquely emitting one of primary color lights such as red, green and blue lights. Such uniquely emitting organic materials are well-known to a person having ordinary skill in the art. Typically, an OLED display displays images by spatially adding the monochromatic primary color lights emitted from energized light emitting members **370**. Hereinafter, the pixels representing red, green, and blue lights are referred to respectively as red, green, and blue pixels and denoted respectively by R, G, and B.

[0033] Light emitting member **370** may have a multilayered structure including an emitting layer (not shown) for emitting light and auxiliary layers (not shown) for improving the efficiency of light emission of the emitting layer. The auxiliary layers may include an electron transport layer (not shown) and a hole transport layer (not shown) for improving the balance of the electrons and holes. The auxiliary layers also may include an electron-injecting layer (not shown) and a hole-injecting layer (not shown) for improving the injection of the electrons and holes. Common electrode **270** can be formed on light emitting member **370** and partition **361**. Common electrode **270** can be supplied with common voltage V_{ss} , and can be made of reflective metal, including without limitation, Ca, Ba, Mg, Al, and Ag, or of a transparent material, including without limitation, ITO and IZO.

[0034] In the above-described OLED display, first control electrode **124a** connected to a gate line **121a**, a first input electrode **153a** connected to a data line **171a**, and a first output electrode **155a** along with a projections **154a** of a semiconductor stripe **151** form a switching TFT Qs having a channel formed in projection **154a** disposed between first source electrode **173a** and first drain electrode **175a**. Likewise, a second control electrode **124b** connected to a first output electrode **155a**, a second input electrode **153b** connected to a driving voltage line **172a**, and a second output electrode **155b** connected to a pixel electrode **191** along with a semiconductor island **154b** form a driving TFT Qd having a channel formed in semiconductor island **154b** disposed between second source electrode **173b** and second drain electrode **175b**. Pixel electrode **191**, a light emitting member **370**, and common electrode **270** form an OLED LD having pixel electrode **191** as an anode and common electrode **270** as a cathode or vice versa. The overlapping portions of storage electrode **127** and driving voltage line **172a** form a storage capacitor Cst.

[0035] Driving transistor Qd in pixels R, G and B shown in FIGS. 2, 3 and 4 occupy different areas. It is because

driving transistors Qd have different channel widths that depend on the emission efficiency of the OLEDs connected thereto. The emission efficiency of the OLEDs is determined by the material. For example, the emission efficiency decreases from green to blue via red. For emitting a given intensity of light, the OLED having lower emission efficiency requires more current and thus driving transistor Qd connected thereto has wider channel width. The channel may be curved or serpentine for obtaining enlarged channel width. The driving current can be also increased by reducing the channel length. Accordingly, driving transistor Qd for green pixel G typically is the largest, that for red pixel R is the second, and that for blue pixel B is the smallest. On the other hand, the areas occupied by the OLEDs of the red, green, and blue pixels R, G, and B are substantially equal to each other for uniform color mixing.

[0036] In this way, different areas of driving transistors Qd and equal areas of the OLEDs lead different sizes of pixels R, G and B. For example, pixels R, G and B shown in FIGS. 2, 3 and 4 have different longitudinal lengths.

[0037] For the most part, the OLED display can be configured to emit the light toward the top or bottom of substrate 110 to display images. A combination of substantially opaque pixel electrodes 191 and a substantially transparent common electrode 270 can be employed to a top emission OLED display that emits light toward the top of substrate 110. For a bottom emission OLED display that emits light toward the bottom of substrate 110, a combination of substantially transparent pixel electrodes 191 and a substantially opaque common electrode 270 can be employed. If made of polycrystalline silicon, semiconductor members 151 and 154b may include intrinsic regions (not shown) disposed under control electrodes 124a and 124b and extrinsic regions (not shown) disposed opposite each other with respect to the intrinsic regions. A person of ordinary skill in the art would be versed in so disposing both the intrinsic region and the extrinsic region. Where extrinsic regions are electrically connected to input electrodes 173a and 173b and to output electrodes 175a and 175b, ohmic contacts 163a, 163b, 165a and 165b may be omitted. Control electrodes 124a and 124b may be disposed over semiconductor members 151 and 154b. Gate insulating layer 140 is still interposed between semiconductor members 151, and 154b and control electrodes 124a and 124b. Selected embodiments of data conductors 171a, 172a, 173b, and 175b may be disposed on gate insulating layer 140 and electrically connected to semiconductor members 151 and 154b through the contact holes (not shown) in gate insulating layer 140. Otherwise, data conductors 171a, 172a, 173b and 175b may be disposed under semiconductor members 151 and 154b and may electrically contact semiconductor members 151 and 154b.

[0038] An exemplary arrangement of the pixels shown in FIGS. 2, 3 and 4 is described with reference to FIG. 6. FIG. 6 shows an arrangement of a plurality of red pixels R, green pixels G, and blue pixels B. Pixels R, G and B can have different longitudinal lengths. As described above, OLEDs of pixels R, G and B can have substantially equal area, while driving transistors of pixels R, G and B can have different areas.

[0039] In one embodiment, pixels R, G and B can be arranged in a matrix. Each row of pixels includes red pixels

R, blue pixels B, and green pixels G that are sequentially arranged and have different longitudinal lengths. Columns of pixels include two types of pixel columns. It is desirable that the first type of pixel columns includes the largest pixels (i.e., blue pixels B) and the smallest pixels (i.e., green pixels G) and that the largest pixels and the smallest pixels be alternately arranged. The second type of pixel columns can include only the middle size pixels (i.e., red pixels R). Conveniently, each of pixel rows can have two opposite boundaries, i.e., a curved boundary and a straight boundary. Accordingly, gate lines 121a, which extend along the boundaries of the pixel rows, can include are alternately arranged, and periodically-curved gate lines and straight gate lines.

[0040] In general, when sum of the longitudinal lengths of smallest pixel G and largest pixel B is twice the longitudinal length of middle size pixel R, the overall arrangement of pixels R, G and B may be a repetition of the arrangement of two rows. The sequence of the emission efficiency of pixels R, G and B may be varied depending on materials of the pixels, and the present invention can be also applied thereto. An embodiment of the present invention suitably arranges the pixels having different sizes corresponding to the emission efficiency of the OLEDs to obtain both desirable current driving characteristics and a desirable aperture ratio.

[0041] Although preferred embodiments of the present invention have been described in detail hereinabove, it should be clearly understood that many variations and/or modifications of the basic inventive concepts herein taught which may appear to those skilled in the present art will still fall within the spirit and scope of the present invention, as defined in the appended claims.

What is claimed is:

1. An organic light emitting diode display comprising:

a plurality of pixels, each pixel comprising a light emitting element and a driving transistor coupled to the light emitting element,

wherein the pixels comprise first pixels, second pixels, and third pixels, the driving transistors of each of the first pixels, each of the second pixels, and each of the third pixels occupy different areas, and the light emitting elements of each of the first pixels, each of the second pixels, and each of the third pixels occupy substantially equal area.

2. The organic light emitting diode display of claim 1, wherein the area of the driving transistor in each of the pixels is determined corresponding to an emission efficiency of the light emitting element in the pixel.

3. The organic light emitting diode display of claim 2, wherein the emission efficiency of the light emitting element in each of the first pixels is higher than the emission efficiency of the light emitting element in each of the second pixels, and the emission efficiency of the light emitting element in each of the second pixels is higher than the emission efficiency of the light emitting element in each of the third pixels.

4. The organic light emitting diode display of claim 3, wherein the first pixels emit green light.

5. The organic light emitting diode display of claim 3, wherein the first pixels emit green light, the second pixels emit red light, and the third pixels emit blue light.

6. The organic light emitting diode display of claim 3, wherein the area occupied by the driving transistor in each

of the first pixels is smaller than the area occupied by the driving transistor in each of the second pixels, and the area occupied by the driving transistor in each of the second pixels is smaller than the area occupied by the driving transistor in each of the third pixels.

7. The organic light emitting diode display of claim 6, wherein sum of the areas of a pair of the first and the third pixels is substantially twice the area of one of the second pixels.

8. The organic light emitting diode display of claim 6, wherein the pixels are arranged in a matrix, and the matrix includes a first column including the second pixels and a second column including the first pixels and the third pixels that are alternately arranged.

9. The organic light emitting diode display of claim 8, wherein the first pixels emit green color light, the second pixels emit red color light, and the third pixels emit blue color light.

10. The organic light emitting diode display of claim 8, wherein each row of the matrix has a curved boundary and a straight boundary.

11. The organic light emitting diode display of claim 1, wherein the driving transistors of the first to the third pixels have different channel widths.

12. The organic light emitting diode display of claim 11, wherein at least one of the driving transistors has a serpentine channel.

13. The organic light emitting diode display of claim 11, wherein the driving transistors comprise polycrystalline silicon.

14. The organic light emitting diode display of claim 1, wherein each of the pixels further comprises a switching transistor, the organic light emitting diode display further comprises a plurality of gate lines and a plurality of data lines, and the gate lines comprise a periodically-curved gate line and a straight gate line that are alternately arranged.

15. The organic light emitting diode display of claim 1, wherein the light emitting element comprises:

- a pixel electrode coupled to the driving transistor;
- a common electrode facing the pixel electrode; and
- an organic light emitting member interposed between the pixel electrode and the common electrode.

16. An organic light emitting diode display comprising:

- a substrate;
- a light emitting element formed on the substrate;
- a driving voltage line formed on the substrate;

a driving transistor coupled to the driving voltage line and the light emitting element;

a gate line and a data line formed on the substrate; and
a switching transistor coupled to the gate line and the data line,

wherein the driving transistor has a serpentine channel.

17. An organic light emitting diode display comprising:

a plurality of pixels arranged in matrix, each pixel comprising a light emitting element and a driving transistor coupled to the light emitting element,

wherein the pixels comprise first pixels, second pixels, and third pixels, the driving transistors of each of the first pixels, each of the second pixels, and each of the third pixels occupy different areas, and the matrix comprises a first pixel column including second pixels and a second pixel column including the first pixels and the third pixels that are alternately arranged.

18. An organic light emitting diode display comprising:

a plurality of pixels arranged in matrix, each pixel comprising a light emitting element and a driving transistor coupled to the light emitting element,

wherein the matrix includes a plurality of pixel rows, each pixel row having a curved boundary and a straight boundary.

19. An organic light emitting diode display comprising:

a plurality of pixels, each pixel comprising a light emitting element and a driving transistor coupled to the light emitting element;

a plurality of gate lines; and

a plurality of data lines,

wherein the gate lines and the data lines are coupled to the pixels and define areas of the pixels, and the gate lines comprise periodically-curved gate lines and straight gate lines that are alternately arranged.

20. An organic light emitting diode display comprising:

a plurality of pixels, each pixel comprising a light emitting element and a driving transistor coupled to the light emitting element,

wherein the pixels comprise a first pixel, a second pixel, and a third pixel, and the first pixel, the second pixel, and third pixel have different lengths in a predetermined direction.

* * * * *

专利名称(译)	有机发光二极管显示器		
公开(公告)号	US20060244696A1	公开(公告)日	2006-11-02
申请号	US11/413240	申请日	2006-04-28
[标]申请(专利权)人(译)	三星电子株式会社		
申请(专利权)人(译)	SAMSUNG ELECTRONICS CO. , LTD.		
当前申请(专利权)人(译)	三星DISPLAY CO. , LTD.		
[标]发明人	JUNG KWANG CHUL JOO IN SU		
发明人	JUNG, KWANG-CHUL JOO, IN-SU		
IPC分类号	G09G3/30		
CPC分类号	H01L27/3211 H01L27/3262 H01L27/3244		
优先权	1020050036756 2005-05-02 KR		
其他公开文献	US7683382		
外部链接	Espacenet USPTO		

摘要(译)

有机发光二极管显示器包括多个像素。每个像素包括发光元件和耦合到发光元件的驱动晶体管。像素可以布置成矩阵。像素包括第一像素，第二像素和第三像素，第一像素至第三像素的驱动晶体管占据不同的区域，并且第一至第三像素的发光元件占据基本相等的区域。

